

Instrumented Environments

Andreas Butz, butz@ifi.lmu.de, www.mimuc.de

Mon, 10-12 Uhr, Theresienstr. 39, Room E 46



Topics today

- A few words on SW infrastructures for IE
- If you took an exam about this lecture, what would I ask?
- If you did a Projektarbeit or Diplomarbeit with me, who could be your advisor?

Thematic map of SW infrastructures

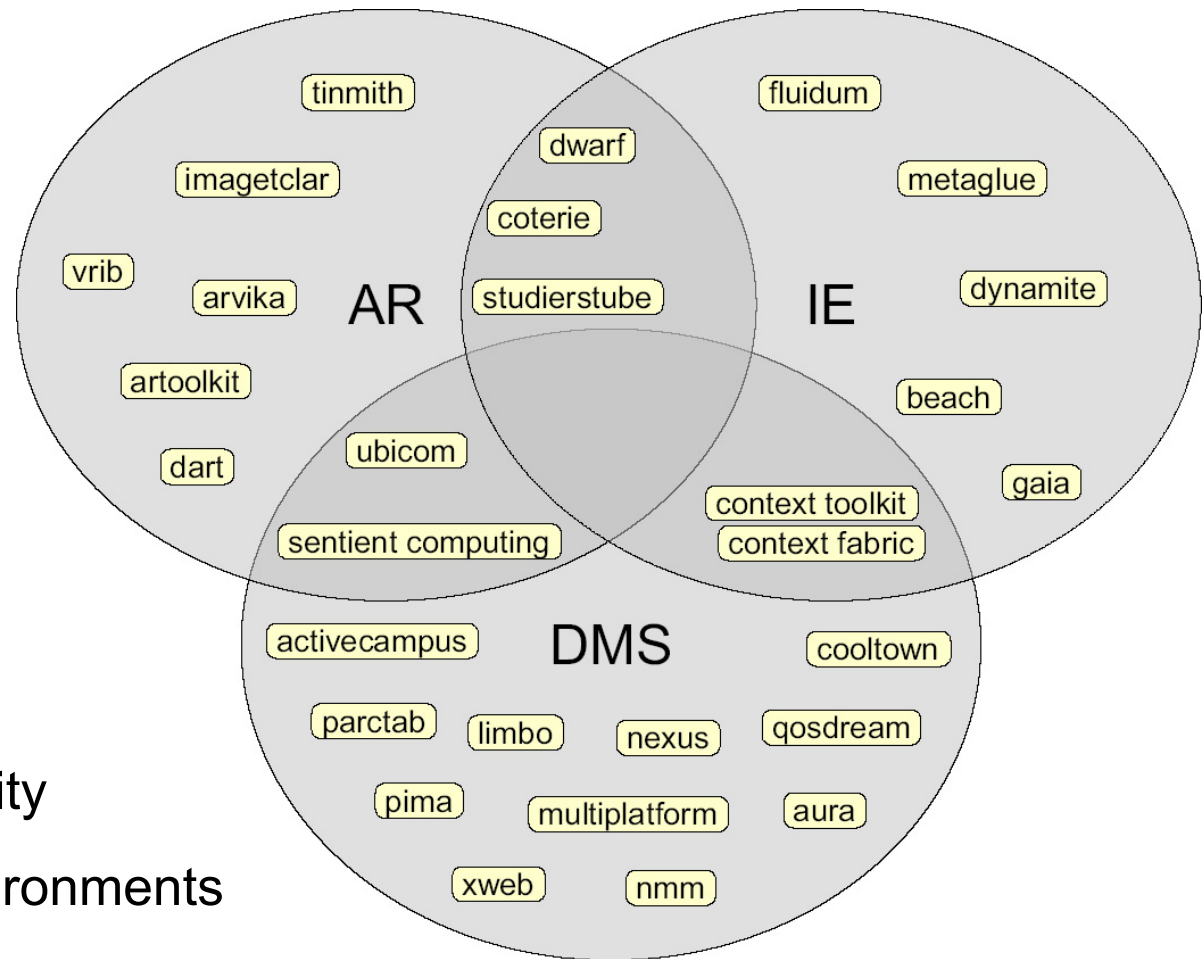

AR = Augmented Reality

IE = Instrumented Environments

DMS = Distributed Multimedia Systems

World map of SW infrastructures



Timeline of SW infrastructures

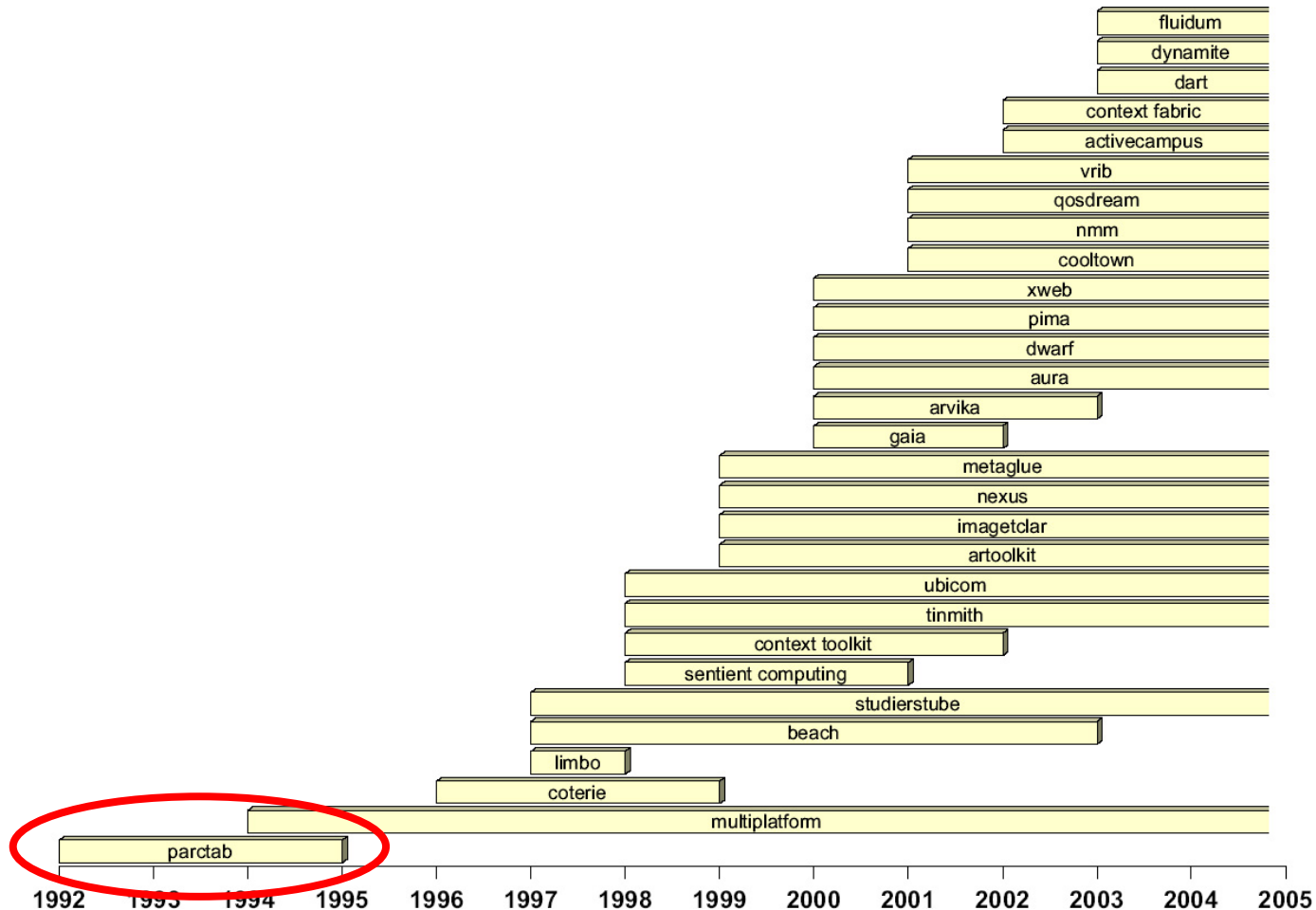

Xerox ParcTab

<http://sandbox.parc.xerox.com/parctab/>

- Infrared network
 - Base stations in the ceiling
- Each base station was controlled by a IR gateway
- Each tab represented by a SW agent (tab agent)
- Applications written in
 - modula-3
 - Tcl/Tk
 - Using MacTabit (~VNC)

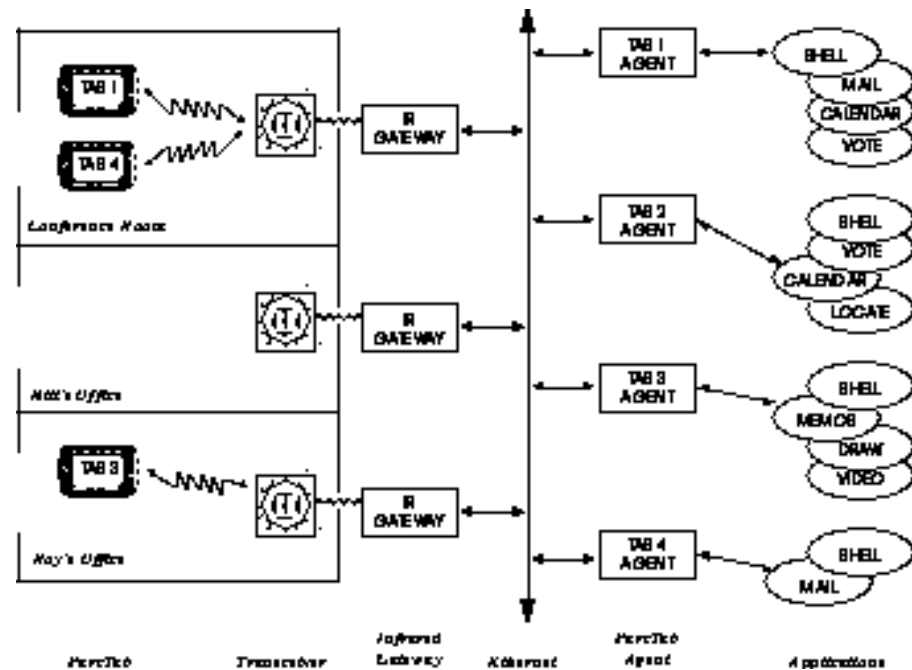
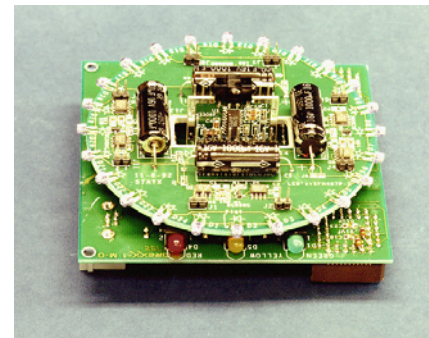

Timeline of SW infrastructures

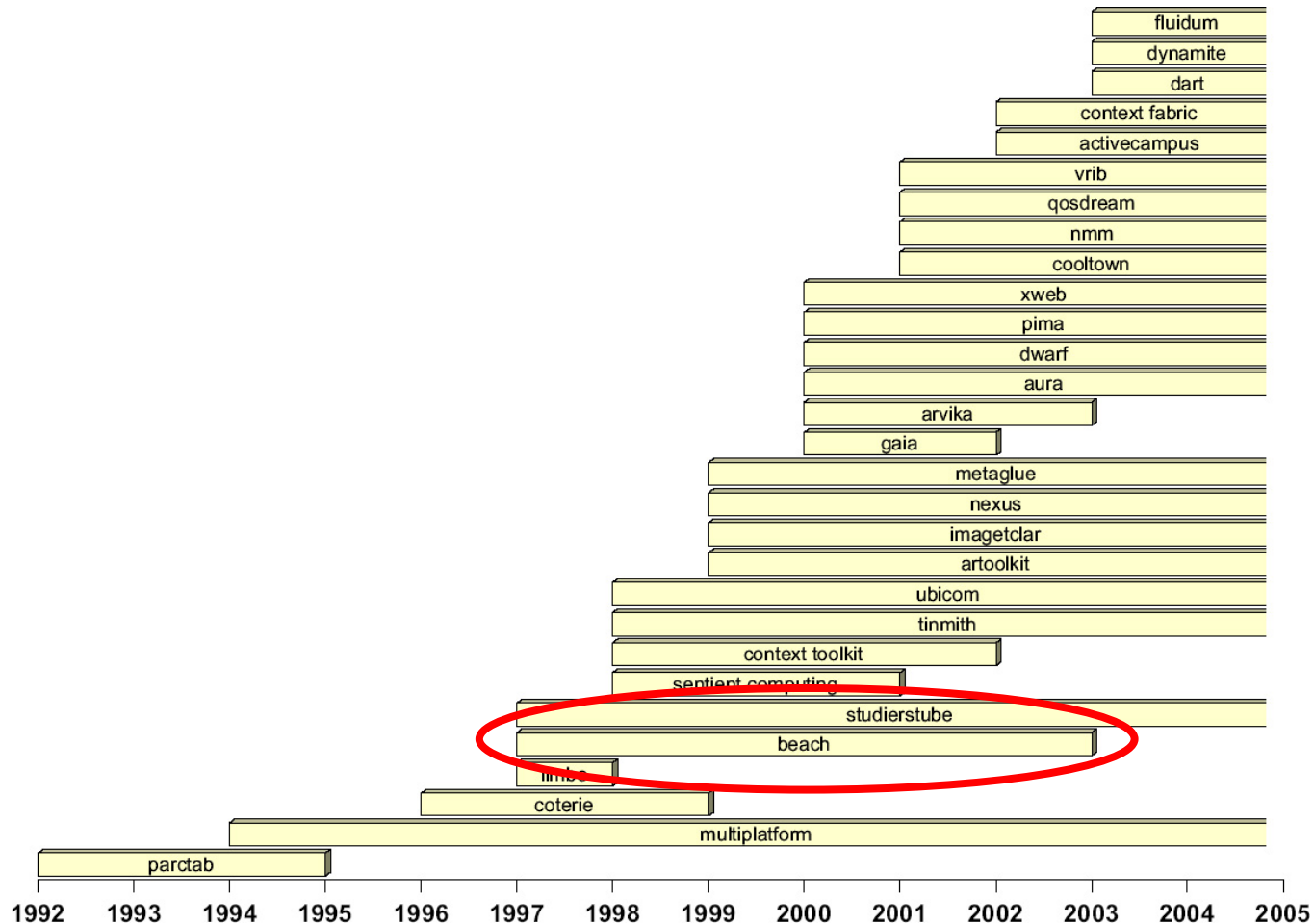

BEACH (FhG IPSI Ambiente)

<http://www.ipsi.fraunhofer.de/ambiente/>

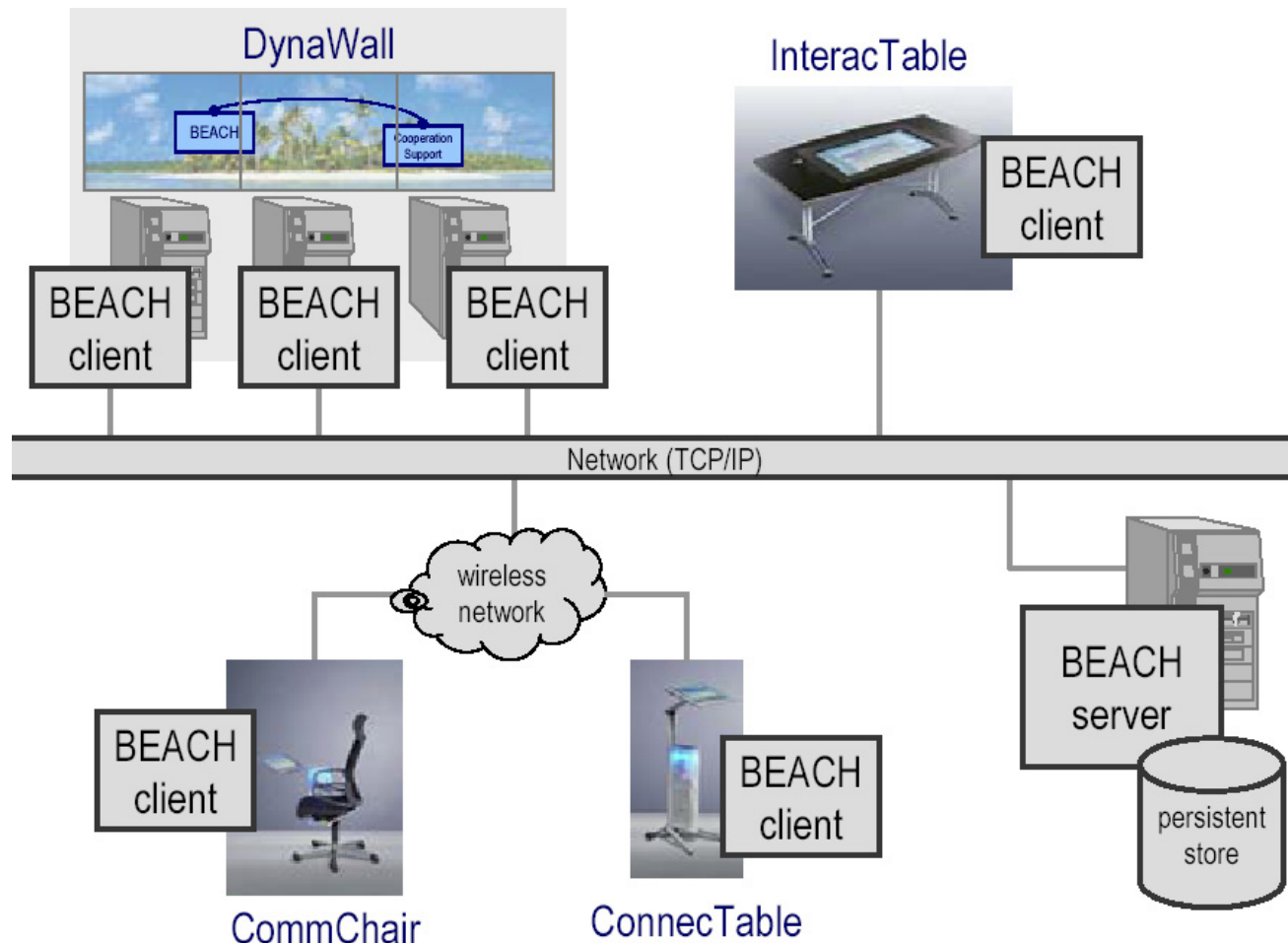

Timeline of SW infrastructures

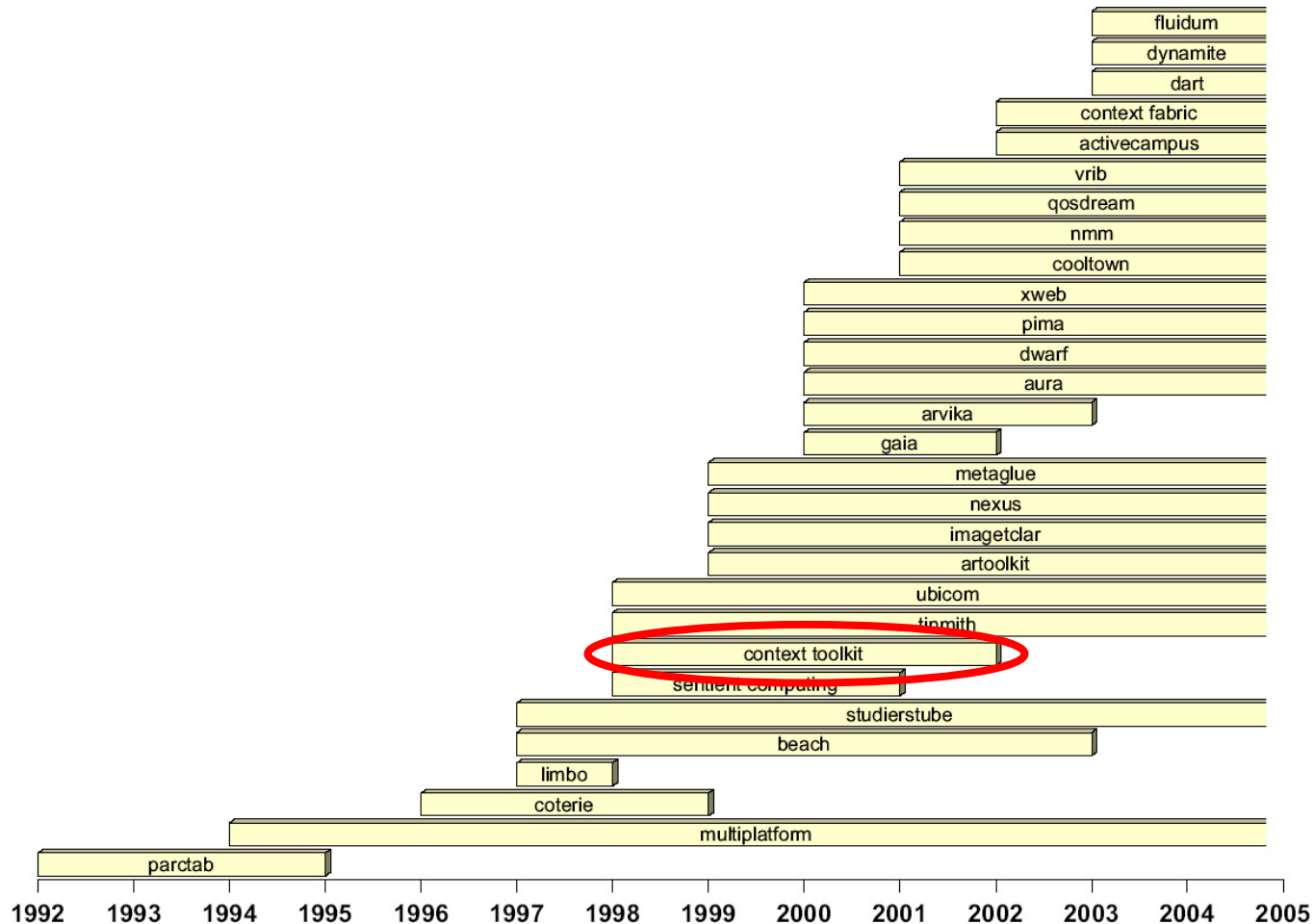

Context Toolkit Framework

- Supports real-world model/methodology and provides library (distributed: XML/HTTP, input-focused)
- Component model: facilitates building of applications in Java

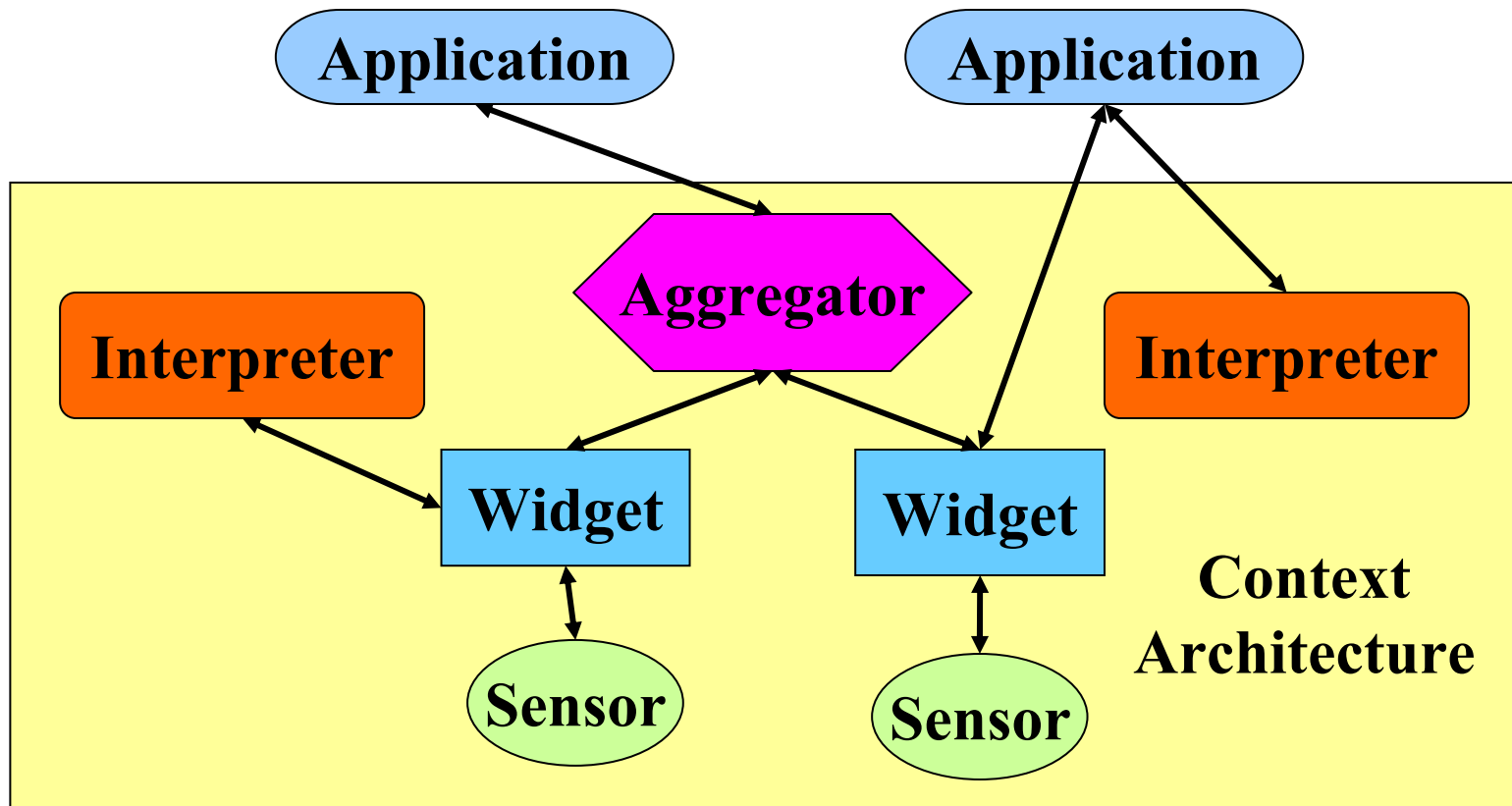

Timeline of SW infrastructures

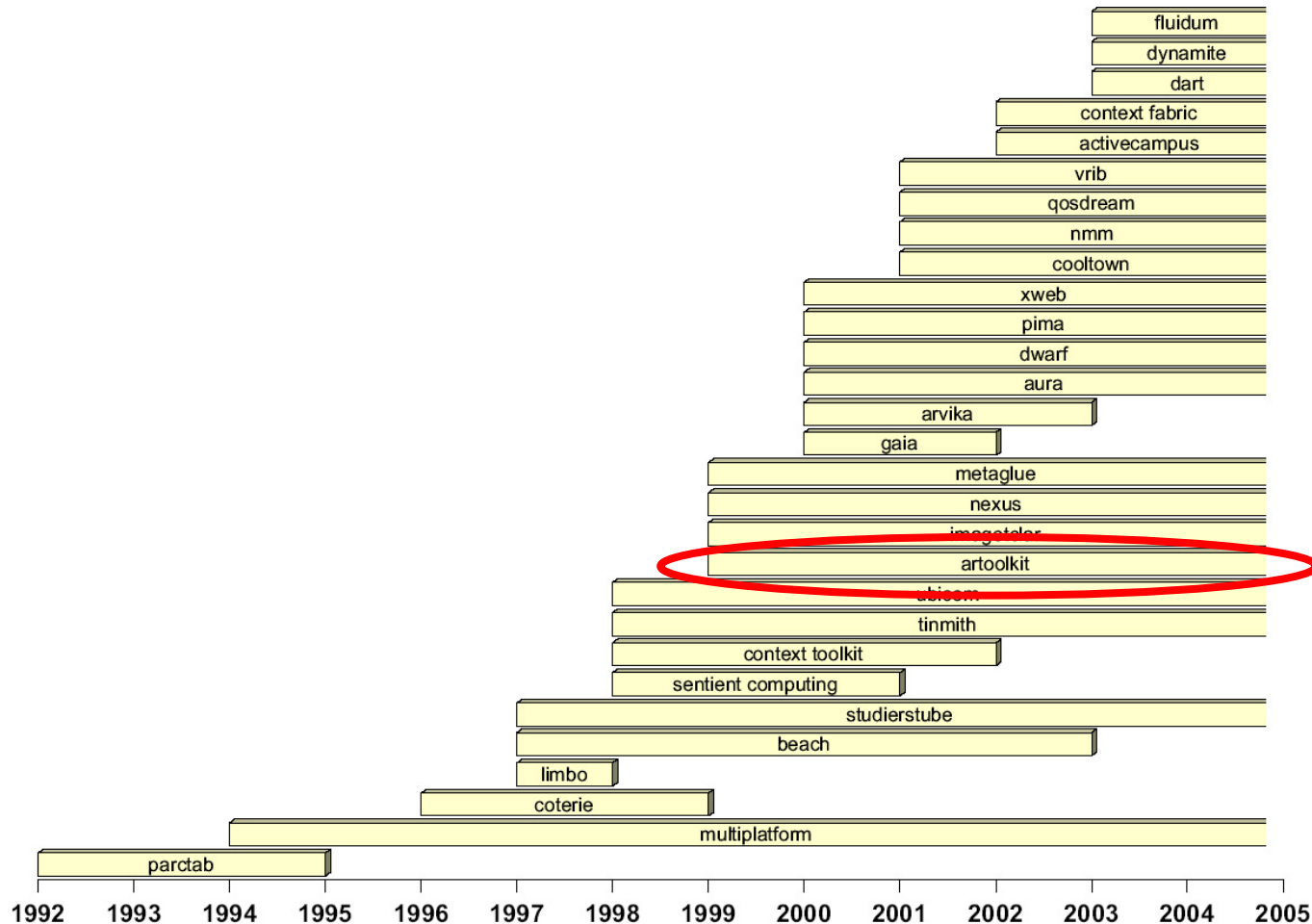

AR Toolkit

- Library for Marker recognition
- Can be used for camera-based tracking
 - With head-mounted displays
 - With other screens
- C library
- Java wrapper available
- Works on
 - Windows
 - Linux
 - PDAs (WinCE)

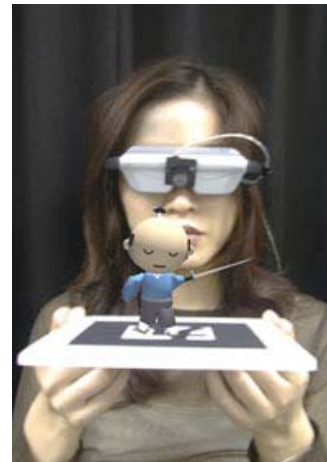

Timeline of SW infrastructures

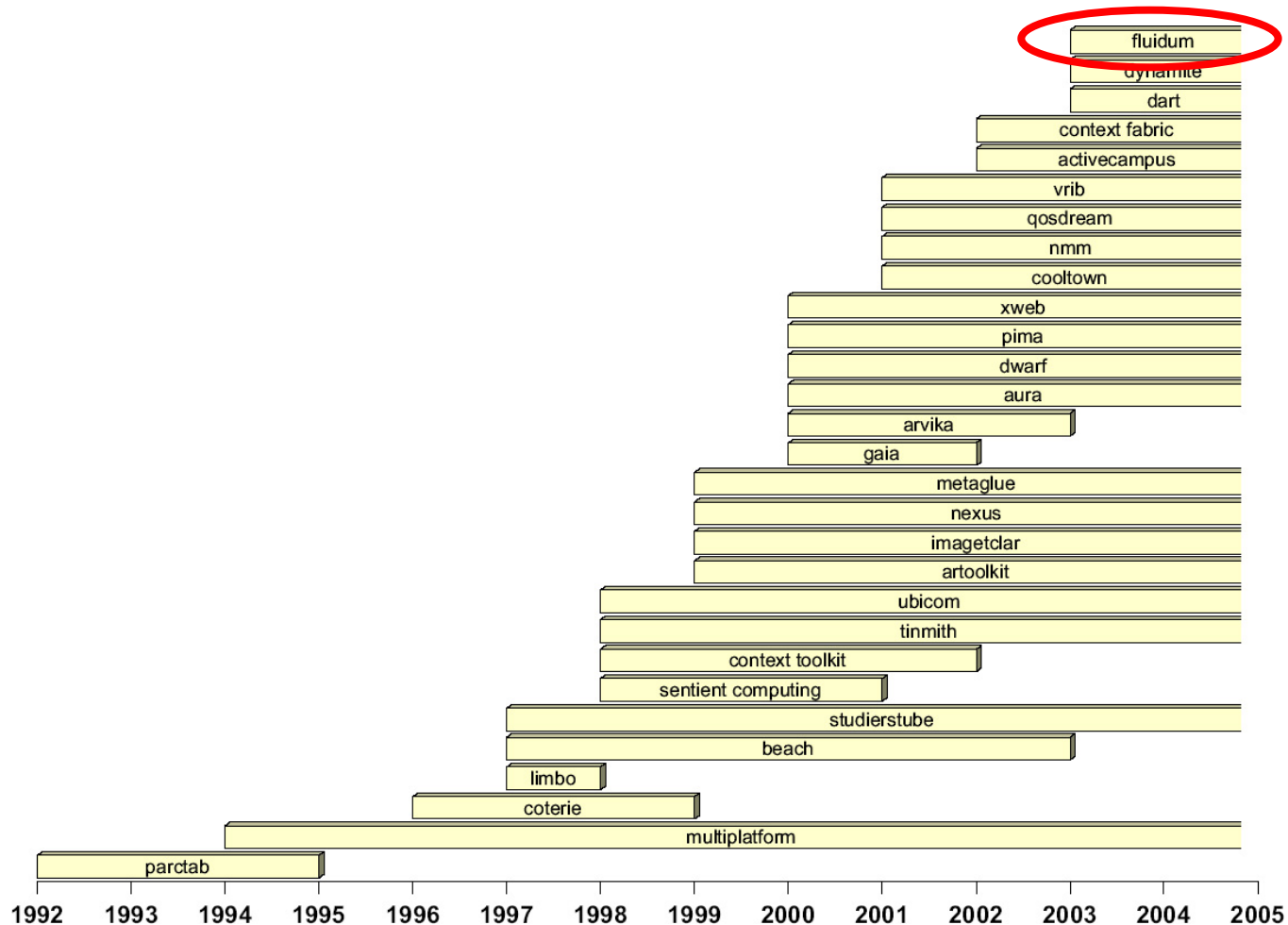

Fluidum SW infrastructure

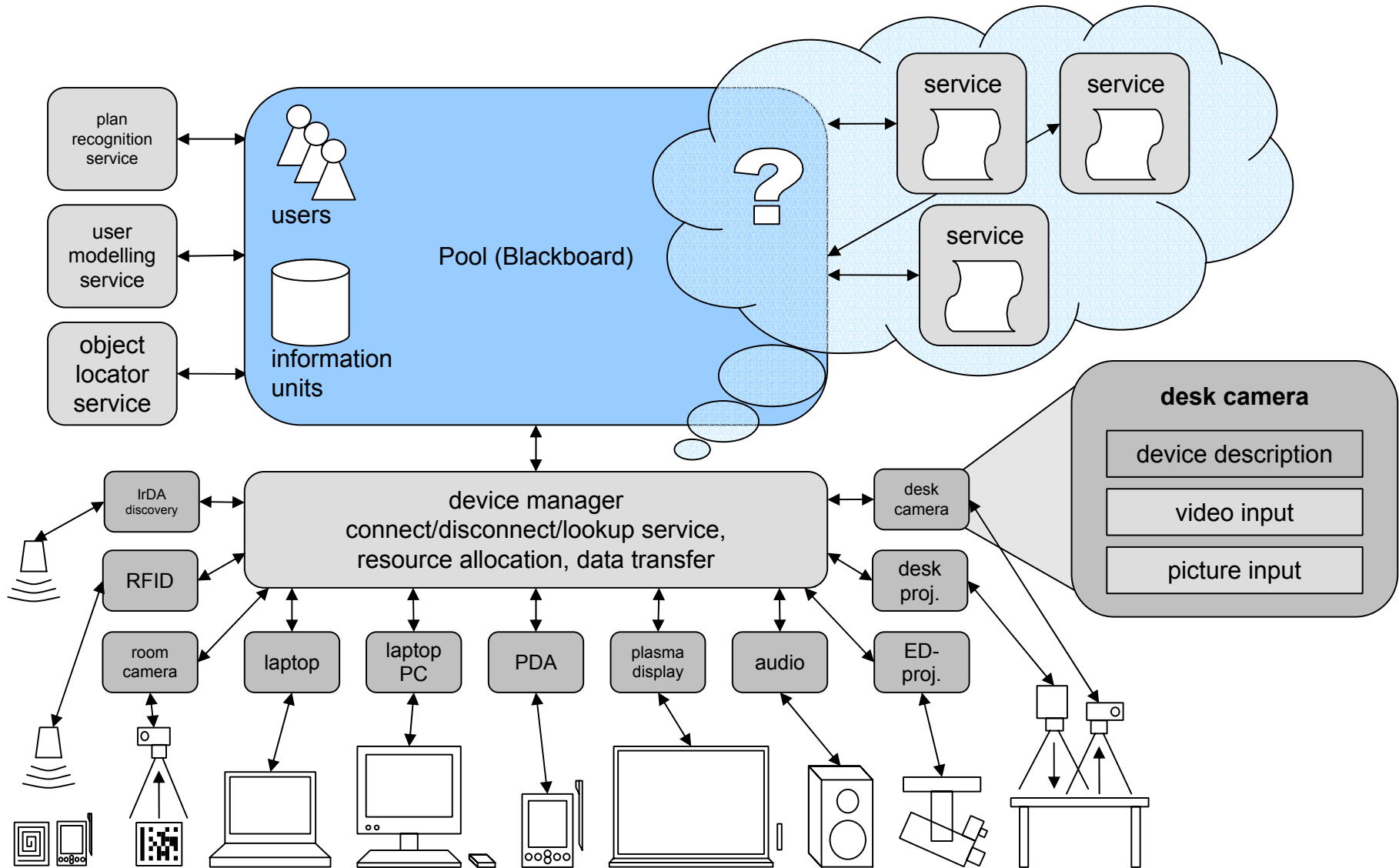

Lecture summary

Important Topics

- Idea of ubiquitous computing
 - Early concepts, Example projects
- Display technologies
 - Working principles, properties
- Network technologies
 - Principles, properties, problems
- Localization technologies
 - Working principles, classes, properties
- Tracking Technologies
 - Working principles, example projects

Important Topics (2)

- Wearable computing
 - Input, output, example applications
- Tangible User Interfaces
 - Classical examples, how they work, what they do
- Ambient User Interfaces
 - Core idea, example TUIs, and how they work
- Context awareness
 - Definitions, formalisms, applications, context toolkit
- Marc Böhlen's guest lecture (bonus material ;-)
 - Core ideas, key findings

Important Topics (3)

- Knowledge representation
 - Different types of KR, representations of time
- Reasoning, planning
 - STRIPS, hierarchical planning
- Multimodal interaction
 - Example projects (Saarland Univ., Sony CSL, Microsoft Research)
 - Criteria for media distribution
 - Cross-media references
- Software infrastructures
 - Only classical examples

These would be your advisors in Fluidum



LMU instrumented room

- In the basement of Amalienstrasse 17
- 12-15m²
- Steerable projector
- Augmented desk
- Back projection wall display
- Conventional displays
- Mobile devices
- Cameras
- Microphones
- RFID/IrDA/BT sensing
- Setup will begin Feb
- Topics for
 - Projektarbeiten
 - Diplomarbeiten
- Ideas for a cool name?
 - SUPIE: Saarland University Pervasive IE
 - Now: MUPIE ??? No!

