

Vorlesung Mensch-Maschine-Interaktion

Ludwig-Maximilians-Universität München

LFE Medieninformatik

Andreas Butz & Albrecht Schmidt

WS2004/2005

<http://www.medien.ifi.lmu.de/>

Butz/Schmidt – Medieninformatik – LMU München – Vorlesung MMI – WS04/05

2004-10-26 – 1

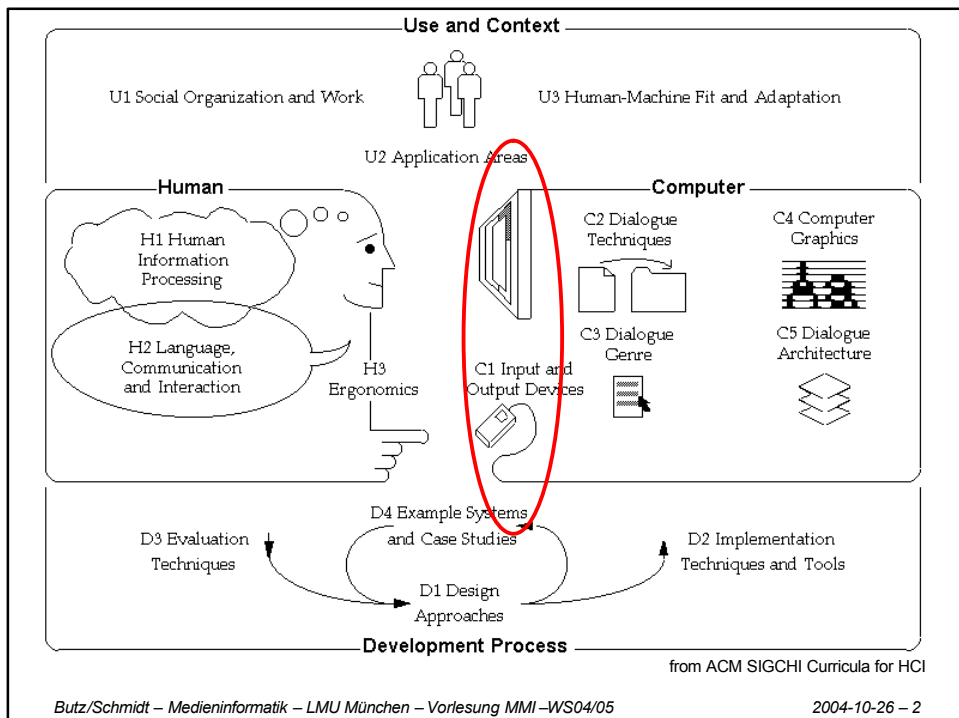

Butz/Schmidt – Medieninformatik – LMU München – Vorlesung MMI – WS04/05

2004-10-26 – 2

Sound and Audio

- Variety of options
 - Beep to multi-channel spatial audio
 - Different technologies
- Output of
 - Information (e.g. click, notification)
 - Auditory icons (e.g. sound for throwing a document away)
 - Earcons – conveying complex information
 - Captured media (e.g. songs, music, films, speeches)
 - Synthesized media (music, spoken text)

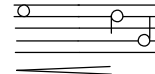
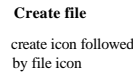
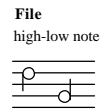
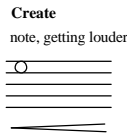

Spatial Audio

- Principle of spatial audio is simple: if the sound waves arriving at your eardrums are identical to those of a real audio source at a particular position, you will perceive that sound as coming from a source at that particular position.
- Because people only have two ears, you only need two channels of sound to create this effect, and you can present this sound over ordinary headphones. It is possible to recreate the effects of the ears and upper body on incoming sound waves by applying digital filters to an audio stream; True binaural spatial audio, when presented over headphones, appears to come from a particular point in the space outside of the listener's head. This is different from ordinary recorded stereo, which is generally restricted to a line between the ears when listened to with headphones
- Headphones are used because they fix the geometric relationship between the physical sound sources (the headphone drivers) and the ears. Headphones also eliminate crosstalk between the binaural signals. With additional signal processing, we can conceivably compensate for these effects, allowing spatial audio to be presented over free field speakers. However, to compensate for the effects of speakers, the spatial audio system must have knowledge of the listener's position and orientation with respect to the speakers

Vector Based Amplitude Panning

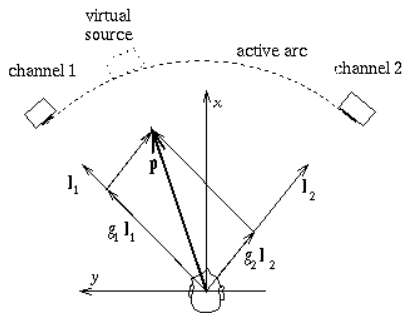

$$\underline{p} = g_1 l_1 + g_2 l_2 = Lg$$

$$g = p^T L^{-1}$$

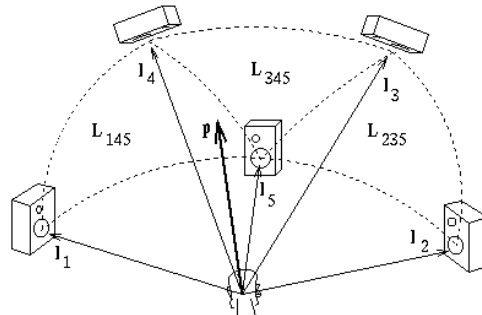

$$\underline{p} = g_1 l_1 + g_2 l_2 + g_3 l_3 = Lg$$

$$g = L^{-1} p^T$$

2D ... 3D

2D and 3D Views and Displays

- Everything on a 2D display is 2D!
 - If we see it 3 dimensional we imagine it...
 - Expectations and experience as basis
 - Displaying a projection of a 3D model
- “real” 3D needs requires a image for each eye
 - Happens naturally when looking at 3D objects in physical space
 - Can be simulated by providing a separate image for each eye using technology
- Options to visualize 3D graphics
 - Create a 2D image that the user translates in 3D in his head
 - Provide images (that represent a 3D model from a particular view point) for both eyes
 - Create 3D structures (static or dynamic)

2D drawing: Make it conclusive...

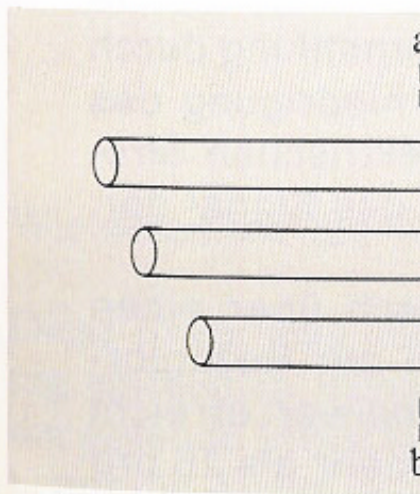

2D drawing: Make it conclusive...

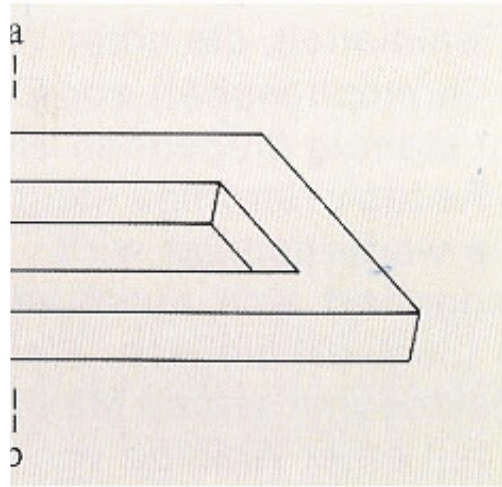

From A. Maelicke, Vom Reiz der Sinne, VCH 1990

Butz/Schmidt – Medieninformatik – LMU München – Vorlesung MMI – WS04/05

2004-10-26 – 9

2D drawing: Make it conclusive...

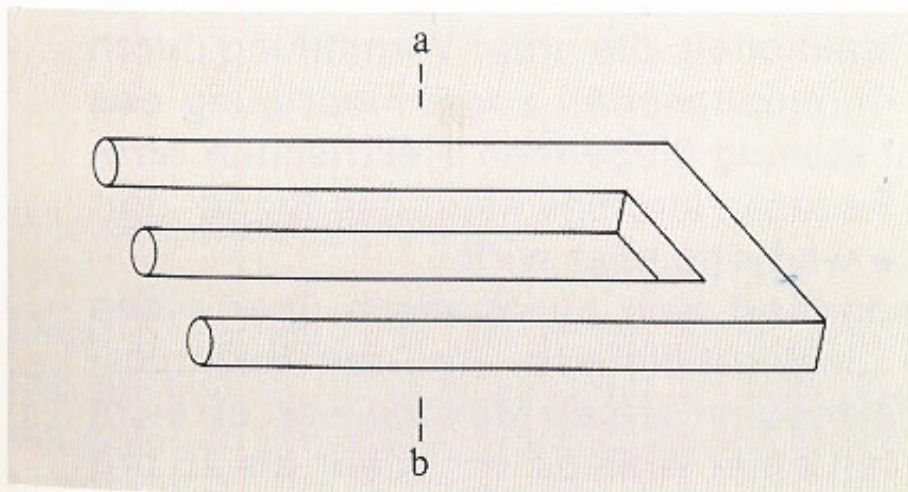

From A. Maelicke, Vom Reiz der Sinne, VCH 1990

Butz/Schmidt – Medieninformatik – LMU München – Vorlesung MMI – WS04/05

2004-10-26 – 10

Stereo 3D Vision Basics

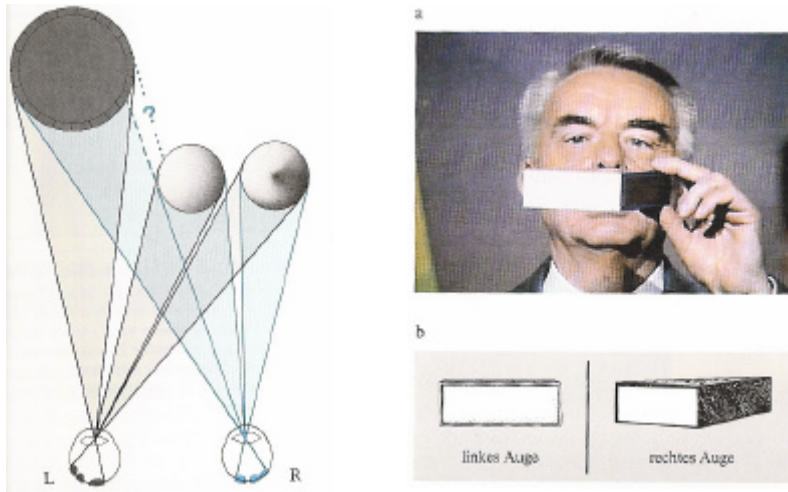

From A. Maelicke, Vom Reiz der Sinne, VCH 1990

Butz/Schmidt – Medieninformatik – LMU München – Vorlesung MMI –WS04/05

2004-10-26 – 11

Stereo 3D Vision Basics

- Image for each object is dependent on the spatial relation between object and observer
 - changing viewpoint changes the images
 - Different people at different view points see different pictures
- Challenges
 - Acquire relation between viewpoint an object
 - Create different images for each eye
 - Deliver different images to each of the eyes
- Approaches
 - Volumetric displays
 - Divided stereo display
 - Autostereoscopic

<http://www.3dcgi.com/cooltech/displays/displays.htm>

<http://fantoma.free.fr/lien3d.htm>

Butz/Schmidt – Medieninformatik – LMU München – Vorlesung MMI –WS04/05

2004-10-26 – 12

Stereo photography stereo vision is not new...

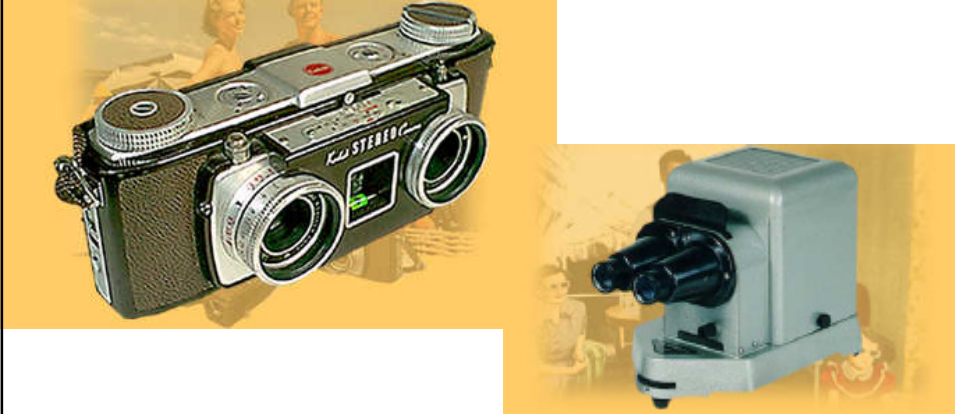

<http://www.stereoblick.de/>

Volumetric 3-D Display

- Creating a volume image – like an objects “Volume-filling imagery”
- Many simultaneous viewers
- Multiple viewpoints,
- Autostereoscopic
- E.g. Perspecta™ 3D
 - Swept-screen multiplanar volumetric display
 - 198 2-D slices
 - 768 x 768 pixel slice resolution
 - 100 million voxels
 - 24 Hz volume refresh
 - 10" diameter spherical image
 - 8 colors at highest resolution
 - Viewing Angle: 360° horizontal, 270° vertical

<http://actuality-systems.com/>



Theory of operation high speed projection (5000 fps)

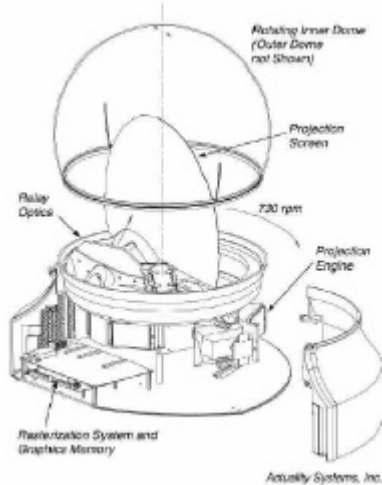

http://actuality-systems.com/index.php/actuality/products/whitepapers/100_million_voxels

Butz/Schmidt – Medieninformatik – LMU München – Vorlesung MMI – WS04/05

2004-10-26 – 15

3D Visions – Basics

<http://www.3d-brillen.de>

- Flash examples...

Butz/Schmidt – Medieninformatik – LMU München – Vorlesung MMI – WS04/05

2004-10-26 – 16

Separate displays for each eye

- Stereoscopic 3D computer imaging
- Separate displays
- E.g. i-glasses SVGA
 - Resolution: 800 x 600
 - Pixels: 1.44 Million per Display
 - Field of View: 26 Degrees
 - Color Depth: 24 Bit
 - Refresh Rate: 120hz



Electro optical shutter

- E.g. CrystalEyes
 - electro-optical shutters
 - wireless active eyewear
 - infrared emitter is placed at the monitor and broadcasts synchronization information to the eyewear.
 - The system works seamlessly so the user sees stereoscopic image



Linear polarization filters and spectacles for 3D projection

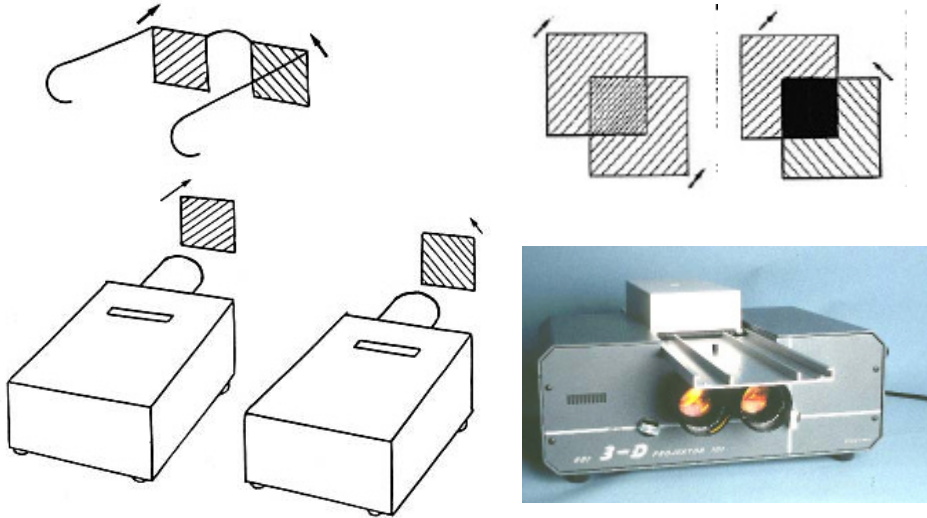

Butz/Schmidt – Medieninformatik – LMU München – Vorlesung MMI –WS04/05

2004-10-26 – 19

Dresdener 3D Display

- Auto stereoscopic display
- no special glasses
- high resolution
- Full brightness display
- tracking system that allows the user to move naturally while working but without losing the 3D effect.

http://www.seereal.com/docs/SeeReal_Stereo_Implementation.zip



Butz/Schmidt – Medieninformatik – LMU München – Vorlesung MMI –WS04/05

2004-10-26 – 20

Dresdener 3D Display basic Technology

- Tracking of users position
- camera or infrared (requires reflector) based
- Moveable prism provided two views
- Alternating columns for left and right eye

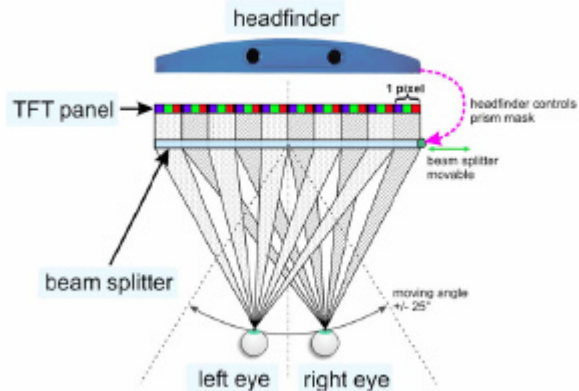

Printing

Printing & Printers

- Printing text, graphics, and photos
- Total cost - dependent on usage/user profile
 - printer price
 - materials (e.g. paper, ink, toner, energy)
 - maintenance (e.g. changing of paper in a ticket machine)
- Hardware
 - Media size and type, e.g. paper A4, CD, card board, envelopes
 - Media handling, e.g. paper container, rolls and cutting
 - Speed – e.g. pages/minute, characters per second, sq ft/h
 - Resolution – typically dpi (dots per inch)
 - Colors
 - Print technology e.g. laser, dot-matrix, ink-jet, thermo
 - Connectivity e.g. network, USB, ...
 - Size, weight, noise, ...
- Software
 - Printer language, e.g. PS (postscript), HPGL (Hewlett-Packard Graphics Language, plotter), PCL (printer command language), GDI (Graphical Device Interface)

Some Printing Technologies

- laser (black/white and color)
 - creating standard documents
 - office use
 - high resolution
- dot-matrix
 - Point of sale
 - Ticket printers
 - Multiple copies (e.g. carbon copy slip for credit card payment)
- Thermo printer
 - Point of sale
 - Ticket printers
 - Mobile printers



Adobe Postscript

- PostScript is a programming language optimized for printing graphics and text
- device independent description
- Instructions for drawing curves, lines, text in different styles, scaling, ...
- stack-based, e.g. "12 134 mul"

```
%!  
% Sample of printing text  
  
/Arial findfont      % Get the basic font  
72 scalefont         % Scale the font to 20 points  
setfont              % Make it the current font  
  
newpath              % Start a new path  
50 200 moveto        % Lower left corner at (100, 200)  
(Hello World!) show  % Typeset "Hello, world!"  
  
showpage
```

2D Printer

- Different technologies, e.g.
 - Laser (B/W and Color)
 - Ink jet
 - Plotter
- Postscript as language
- Not just paper, e.g.
 - Laser cutter
 - Sewing machine



SUPER GALAXIE 3100D



Stereolithography

- The Stereolithography process is basically performed in the following way:
 - Create a 3D model with CAD software.
 - Stereolithography software slices up model into layers; about 5-10 per millimeter.
 - 3D printer (Stereolithography machine) "paints" one of the layers by exposing the liquid polymer in the tank to the laser and hardens it.
 - The platform drops down into the tank layer by layer until the model is completed.
- There are 4 main parts of the Stereolithography Machine:
 - Liquid Photopolymer Tank: holds liquid plastic sensitive to ultraviolet light
 - Perforated Platform: the platform is immersed in the tank and can be moved up and down as the process is performed.
 - Ultraviolet Laser: transforms the liquid polymer into the 3D object.
 - Computer: controls the laser and movement of the platform during the printing process.

<http://www.what-is-injection-molding.com/stereolithography.aspx>

Stereo- litho- graphy

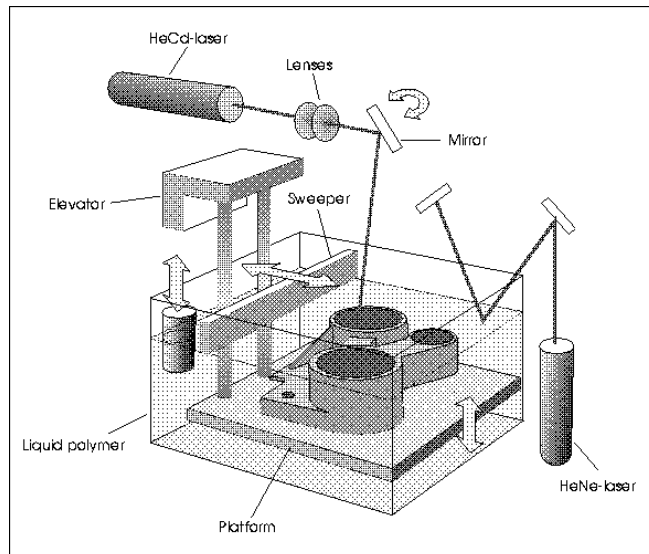
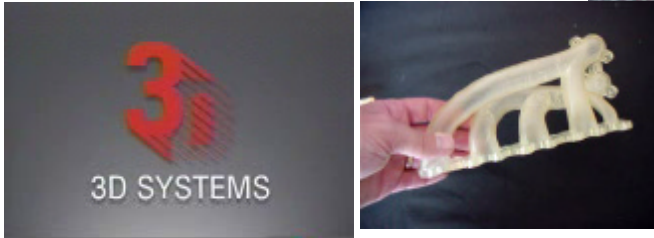

FIGURE 1. A schematic drawing of an SLA.

http://www.cs.hut.fi/~ado/rp/subsection3_6_1.html

Stereolithography Example System

- <http://www.3dsystems.com/products/sla/tour/movtest.asp>
- SLA 7000
 - Layer thickness 0.025 mm – 0.127mm
 - Maximum drawing speed: 2.54 m/sec - 9.52 m/sec
 - Max part weight 68 kg (150 lb)
 - Max build envelope 508 x 508 x 584 mm
- <http://computer.howstuffworks.com/stereolith3.htm>



3D Printer

- *Printing in layers*
- *Different materials*
- *Different colors*
- *Build Speed:*
 - 2-6 layers per minute
- *Build Volume:*
 - 203 x 254 x 203 mm
- *Layer Thickness:*
 - 0.076-0.254 mm)
- *Different formats, e.g. VRML import*

z406 System

Premium high-speed full-color printing.



Quickly print models
of any complexity
in full color!

- <http://www.zcorp.com/products/printersdetail.asp?ID=2>
- video

3D Printer basic principle

- Powder is spread in a thin layer
- Print head spray the binder on the particles
- Repeat for each layer

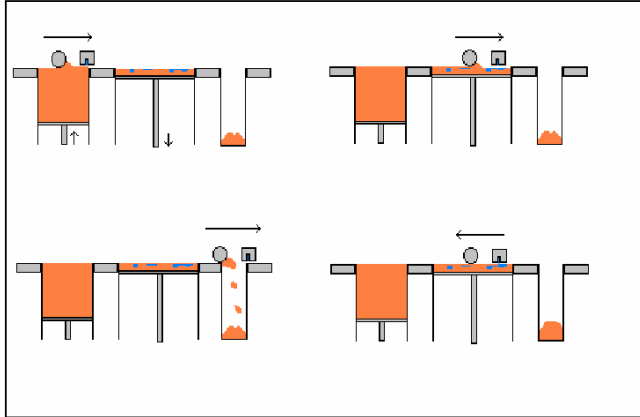

http://www.fmf.uni-freiburg.de/service/sg_surface/pfister-project.pdf

3D Printer (example printout)



- *3D Ribosome-Model*
- <http://www.biol.ethz.ch/dienstleistungen/digitalwerkstatt>

User Interfaces for Authentication

- Categories
 - Password based
 - Token based – ID and Authentication in one go
 - Biometric – ID and Authentication in one go
 - Recall based, e.g. Images
- Parameters
 - False acceptance rate (FAR) – accepting user who should not be allowed in
 - False rejection rate (FRR) – rejecting user who should get in
- High FRRs reduce usability
- High FARs reduce security
- Trade-Off between FAR and FRR

Examples of Biometric Authentication

- Fingerprint
- Hand geometry
- Iris / Retina
- Voice
- Face
- Signature

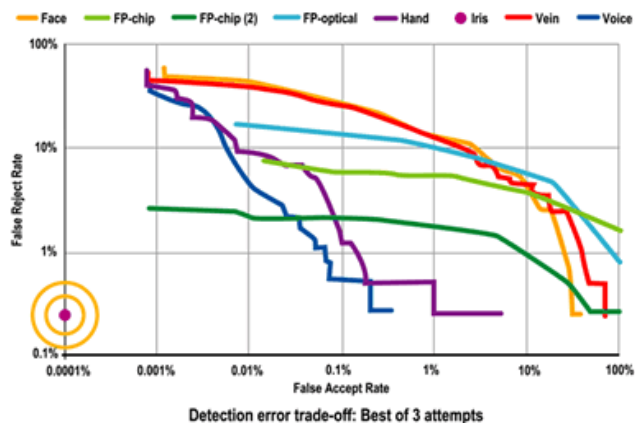

Source: http://www.argus-solutions.com/iris_howitworks.htm

Selected Issues with Biometric Authentication

- How to use it
 - What to do? Instructions?
 - Feedback: Did it work? What went wrong?
- User acceptance
 - Data protection, privacy
 - Related to use (hygienic, convenience, ...)
- Usability
 - Speed (total operation time), reliability
 - Finger: what finger, position, where is the sensor?
 - Iris: height adjustment, which eye, user distance
- Further issues
 - Cultural issues: e.g. Veil and face recognition?, Gloves and Finger print?
 - Injuries: e.g. burns on finger
 - Changes in appearance: contact lenses, make-up, ...

Recall Based Authentication

- Dhamija, R. (2003). Déjà Vu: Using Images for User Authentication. Project Homepage, visited 2004-02-15. <http://www.sims.berkeley.edu/~rachna/dejavu/>
- A. Schmidt, T. Kölbl, S. Wagner, W. Straßmeier (2004). Enabling Access to Computers for People with Poor Reading Skills. User Interfaces for All (UI4ALL), Wien, June 2004



Login für Email - Passbilder - Microsoft Internet Explorer

Datei Bearbeiten Ansicht Favoriten Extras ?

Passbilder für Login

Albrecht



1

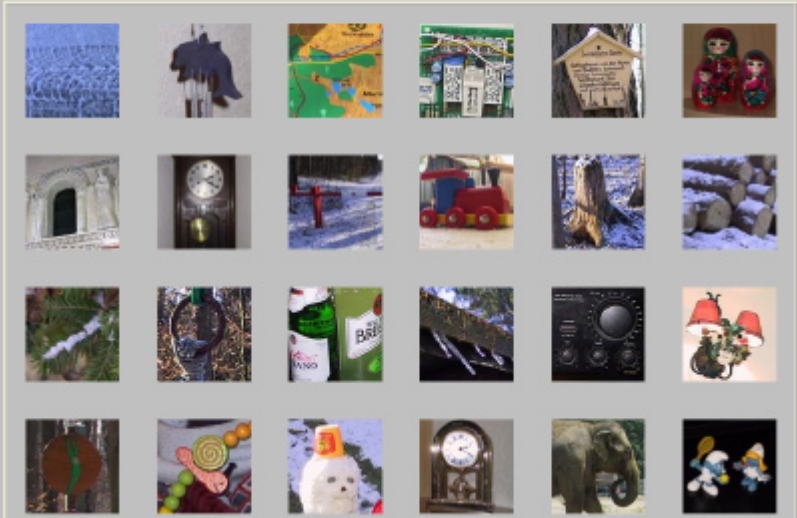

Butz/Schmidt – Medieninformatik – LMU München – Vorlesung MMI –WS04/05

2004-10-26 – 37